

I-PRO 1 BOWL, WITH MECHANICAL CONTROL



LED
Lights



**Ref: 562938
(IPRO1M)**

Slush and sherbet machine, with 1x11-litres lighted and insulated bowl I-Tank, mechanical control, refrigerant gas R290

General Features

I-PRO 1 MECHANICAL is a professional slush machine with n. 1 I-Tank insulated bowl with a capacity of 11 litres, and mechanical control.

Every detail has been studied to create a unique equipment thanks to the numerous patents and innovations available for this model.

This equipment has the I-Tank insulated tank as standard. The shape of the tank guarantees a natural mixing effect, for an optimal consistency of the product.

The look of this equipment is modern and eye-catching, thanks to the LED-light system that illuminates the product inside the tank.

The equipment can dispense slushies, milkshakes, cold drinks and frozen drinks.

I-PRO is an ideal slush machine for bars, amusement parks, fast food chains, kiosks, restaurants, water parks and much more.

I-PRO 1 BOWL, WITH MECHANICAL CONTROL

Specifications

- The ITANK™ Technology prevents ice accumulation on the outer side of the bowl, reducing condensation and increasing the cooling power of the machine.
- Ideal for the production of slush.
- Bowl shape allows a natural mixing action to ensure an optimum consistency of the product.
- Customizable lid merchandiser and back graphic.
- Ideal for operators who want an innovative and distinctive equipment. Mechanical keypad allows for setting of cooling and defrost modes.
- Optionals available: autofill lid (pre-mix or post-mix) for the automatic filling of the tanks.

Construction

- Electromechanical control.
- Sliding drip tray.
- The mechanical control allows you to manually set the “production mode” and the “night mode”.

I-PRO 1 BOWL, WITH MECHANICAL CONTROL

Electric

Supply voltage:	220-240 V / 1 ph / 50 Hz
Electrical power max.:	0.54 kW
Current consumption:	2.8 Amps
Plug type:	CE-SCHUKO

Key Information:

Number of bowls:	1
Bowl's capacity:	11 lt
Control board:	Mechanical
Dimensions, Width:	200 mm
Dimensions, Depth:	580 mm
Dimensions, Height:	870 mm
Net weight:	39 kg

Refrigeration Data

Refrigerant gas:	R290
------------------	------

Certifications



The company reserves the right to make modifications to the products without prior notice. All information correct at time of printing.

2026.03.31

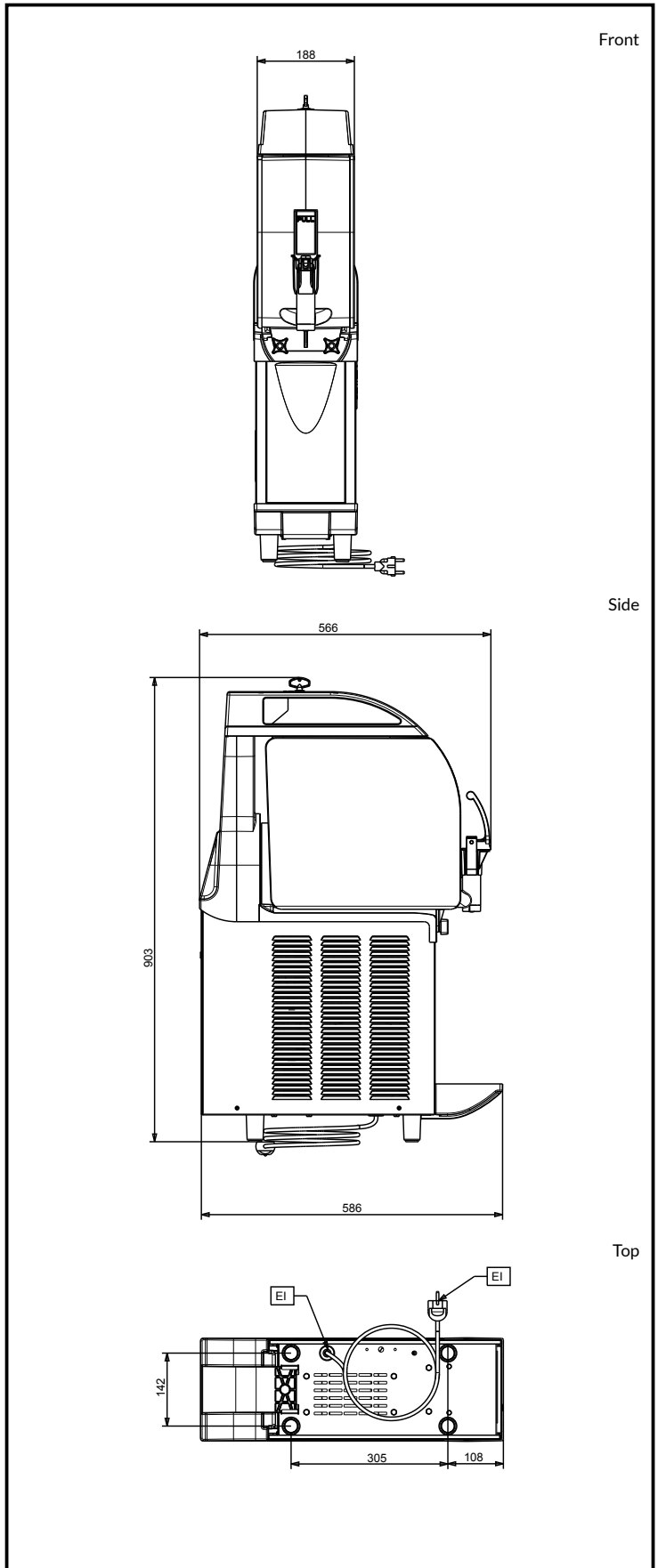

CRATHCO

www.crathco.drink-systems.com
infocrathco@electroluxprofessional.com